



AUTOMA 3-piece body is full bore design with straight through flow. 3-piece body allows easy maintenance service without removing end cap from pipe line. The body is made of investment casting and the valve is featured with blow-out-proof stem. Suitable for isolation applications in the Food Industries, Palm Oil and Refinery, Rubber Glove, Power, Oil and Gas, Petrochemical Industries and Genral Industrial Plants.

FEATURES:

- Direct mounting without bracket and adaptor

- Blow-out-proof stem

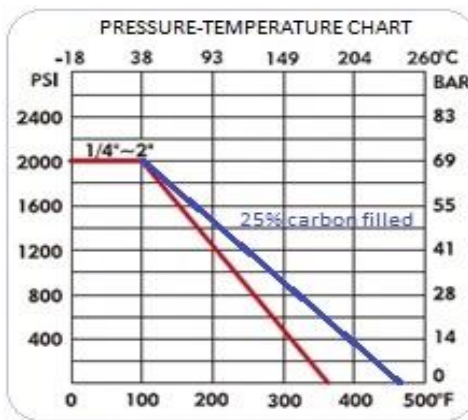
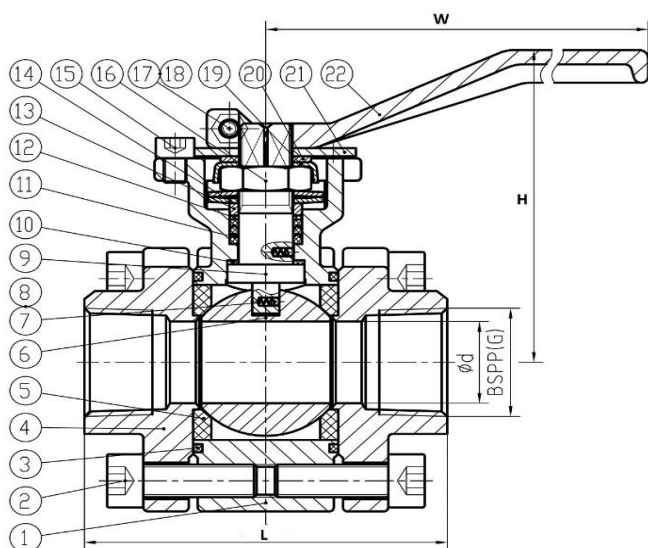

DIMENSIONS

SIZE		d	L	H	W
DN	G				
15	1/2	15	75	54	105
20	3/4	20	80	66	120
25	1	25	90	72	140
32	1-1/4	32	110	81	155
40	1-1/2	38	120	96	170
50	2	50	140	105	185

PRESSURE TEST

BODY	SEAT	
	by water	by air
210 kg/cm ²	80 kg/cm ²	6 kg/cm ²

MATERIAL LIST

NO.	PART NAME	MATERIAL	
		AT325	AT326
1	Body	CF8M	WCB
2	Bolt	SUS304	A193-B8
3	Gasket	R-PTFE	
4	Cap	CF8M	WCB
5	Seat	25% carbon filled PTFE	
6	Ball	SS316	
7	Spring	SS316	
8	Steel ball	SS316	
9	Stem	SS316	
10	Washer	SS304	
11	Packing 1	R-PTFE	
12	Packing 2	Flexible graphite	
13	Washer	SS304	
14	Belleville spring	SS304	
15	Bolt	SUS304	A193-B8
16	Nut	SUS304	A194-8
17	Bolt	SUS304	A193-B8
18	Nut	SUS304	A194-8
19	Locator	SUS304	
20	Washer	SUS304	
21	Stopper	SUS304	
22	Handle	SUS201	

The specification and dimensions are subject to change without prior notice!