

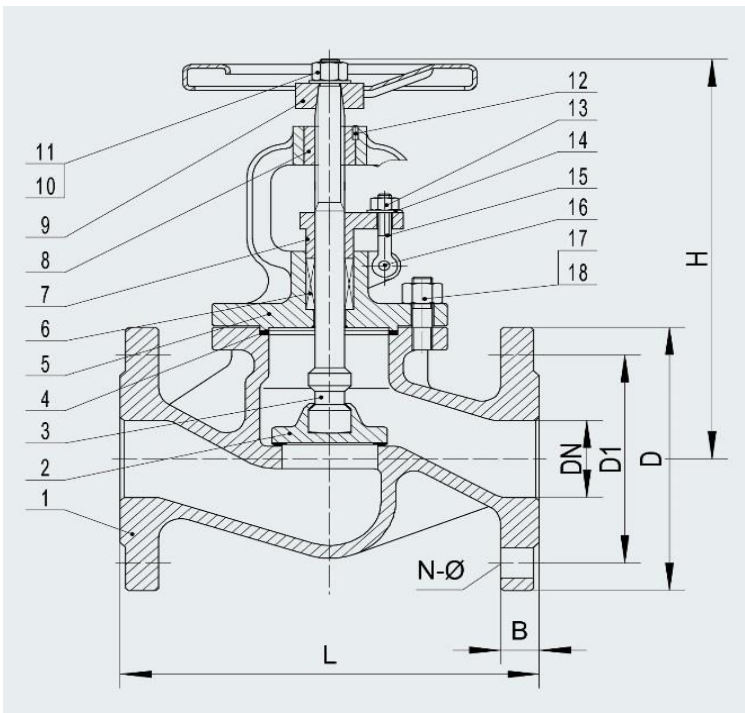

DESCRIPTION:

AUTOMA Globe Valve S-Pattern is designed for high pressure and high temperature applications and used for regulating of flow in a pipeline. This valve can be installed in horizontal or vertical positions in the pipe line system, the flow direction should be in accordance with marking on the body.

- Seat pressure test at 18bar / 44bar for PN40



MATERIAL LIST:

ITEM	PART NAME	MATERIAL
1	Body	GS-C25+13Cr
2	Disc	CS+13Cr
3	Stem	13Cr
4	Gasket	SS304+graphite
5	Cover	GS-C25
6	Gland Packing	Graphite
7	Gland	13Cr
8	Yoke nut	GGG40.3
9	Handwheel	CS
10	Nut	A194-2H
11	Washer	CS
12	Bolt	A193-B7
13	Nut	A194-2H
14	Washer	CS
15	Eye bolt	A193-B7
16	Pin	CS
17	Bolt	A193-B7
18	Nut	A194-2H

DIMENSIONS PN16 (mm):

SIZE	1/2"	3/4"	1"	1-1/4"	1-1/2"	2"	2-1/2"	3"	4"	5"	6"	8"
DN	15	20	25	32	40	50	65	80	100	125	150	200
L	130	150	160	180	200	230	290	310	350	400	480	600
H	180	190	220	222	252	263	290	330	350	420	455	550
D	95	105	115	140	150	165	185	200	220	250	285	340
D1	65	75	85	100	110	125	145	160	180	210	240	295

DIMENSIONS PN40 (mm):

L	130	150	160	180	200	230	290	310	350	400	480	600
H	180	190	220	222	252	263	290	330	350	420	455	550
D	95	105	115	140	150	165	185	200	235	275	300	375
D1	65	75	85	100	110	125	145	160	190	220	250	320

The specification and dimensions are subject to change without prior notice!